

William N. Lamarre Concrete Products, Inc.

4'x4'x4' & 4'x4'x3' GALLEYS

HD Top Loading Only
(Drawings Not to Scale)

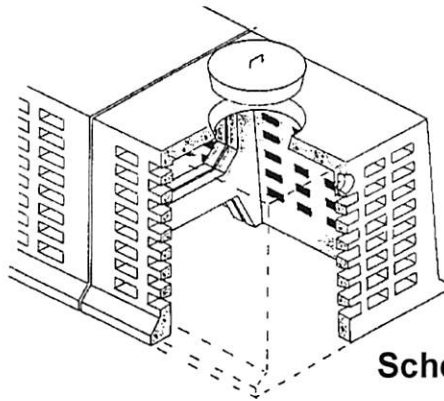

Chamber	Invert
4'x4'x4'2"	40"
4'x4'x3'2"	24"

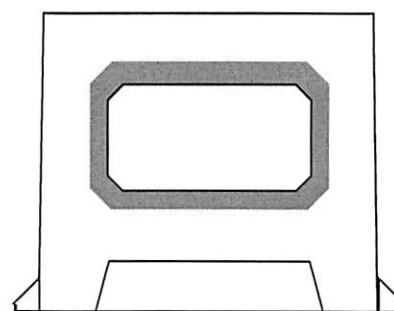
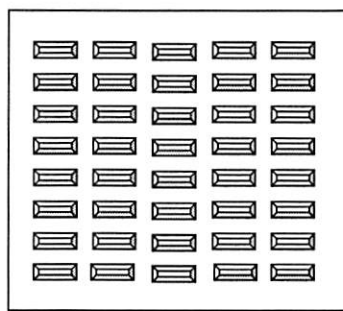
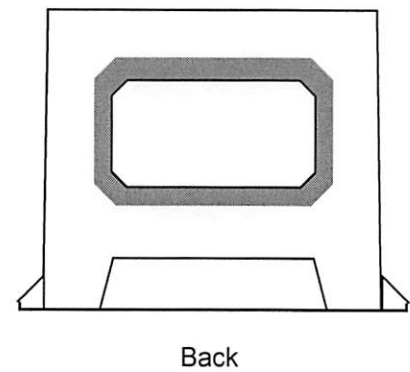
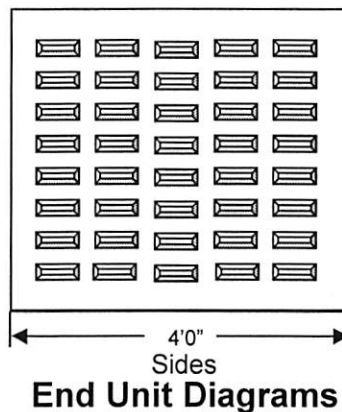
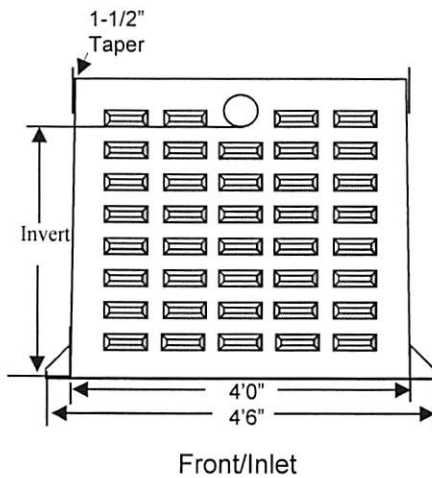

Middle Unit Diagrams

Notes

1. Concrete strength f'c 4000PSI@28 days. Density 150 PCF.
2. Cement, Portland Type II or III, ASTM C150-81
3. Admixtures, air & plasticizers per ASTM C233-82
4. Reinforcement per ASTM C1227-latest revision
5. Conforms to Mass Title V specifications
6. Top thickness is 6", Wall thickness is 3"