

William N. Lamarre Concrete Products, Inc.

H2O TUNNEL TANK

Gallons vary to specifications needed.

Drawing Not to Scale

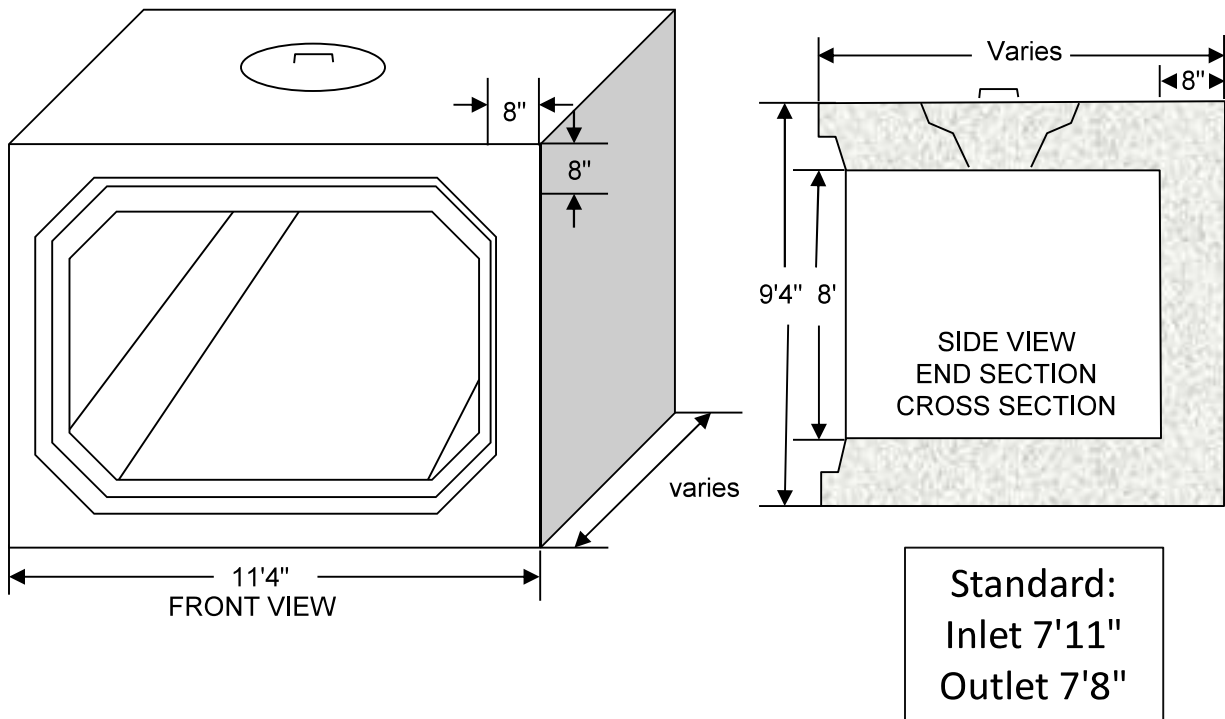
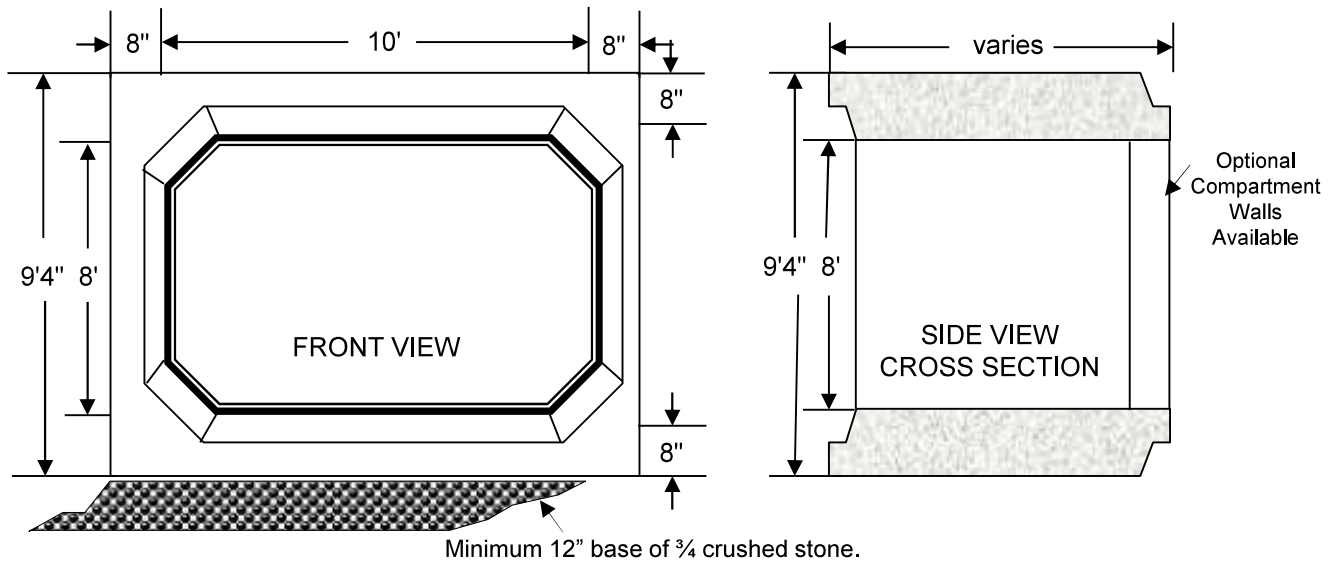

Notes

1. Available 10,000 to 100,000 Gallon Capacity or more.
2. Concrete strength f'c 5000PSI@28 days. Density 150 PCF.
3. Cement, Portland Type II or III, ASTM C150-81
4. Admixtures, air & plasticizers per ASTM C233-82
5. Reinforcement per ASTM C1227-latest revision
6. Design Loading AASHTO HS20-40
7. Constructions joints sealed with butyl rubber
8. Design conforms to 310 CMR 15.00, Mass Title V regs. for septic tanks
9. Access & Piping per job specs.