

William N. Lamarre Concrete Products, Inc. H2O TUNNEL TANK 2-COMPARTMENT

15,000 2/3-1/3 Shown - Gallons & wall placement vary to specifications.

Drawing Not to Scale

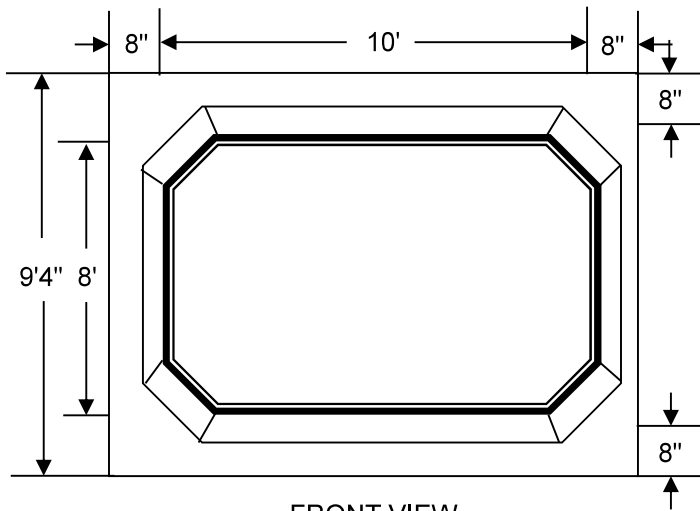
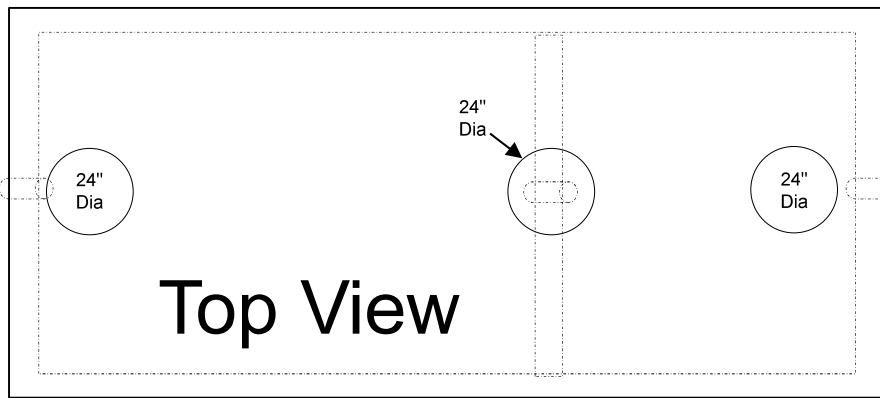
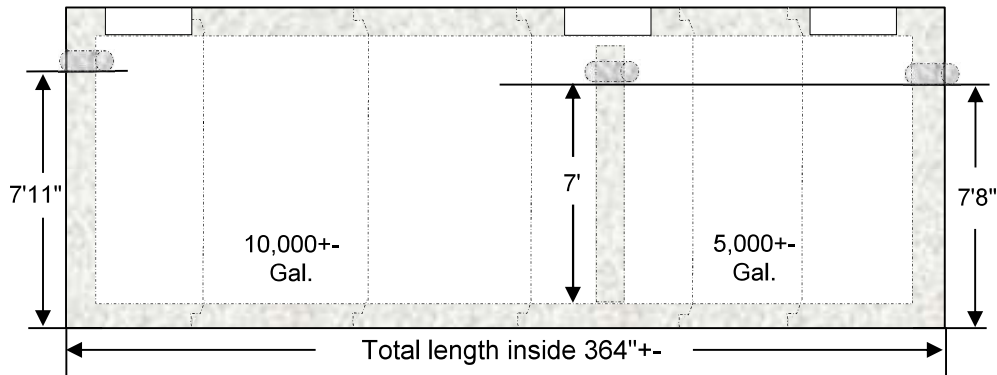

FRONT VIEW

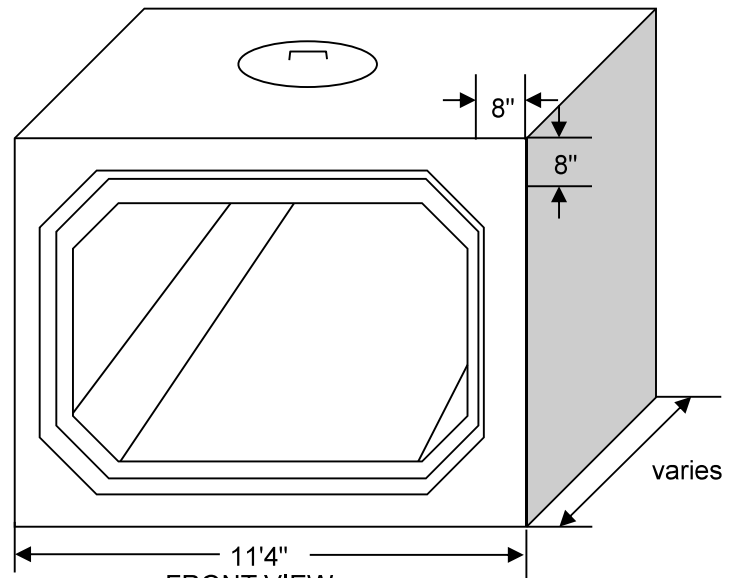

FRONT VIEW

Notes

1. Concrete strength f'c 5000PSI@28 days. Density 150 PCF.
2. Cement, Portland Type II or III, ASTM C150-81
3. Admixtures, air & plasticizers per ASTM C233-82
4. Reinforcement per ASTM C1227-latest revision
5. Design Loading AASHTO HS20-40
6. Construction joints sealed with butyl rubber
7. Design conforms to 310 CMR 15.00, Mass Title V regs. for septic tanks
8. Access & Piping per job specs.