

William N. Lamarre Concrete Products, Inc.

LARGE SIZE DISTRIBUTION BOXES

8 OUTLET (H10 and H20) DISTRIBUTION BOX

(H20 Shown)
(Drawings Not to Scale)

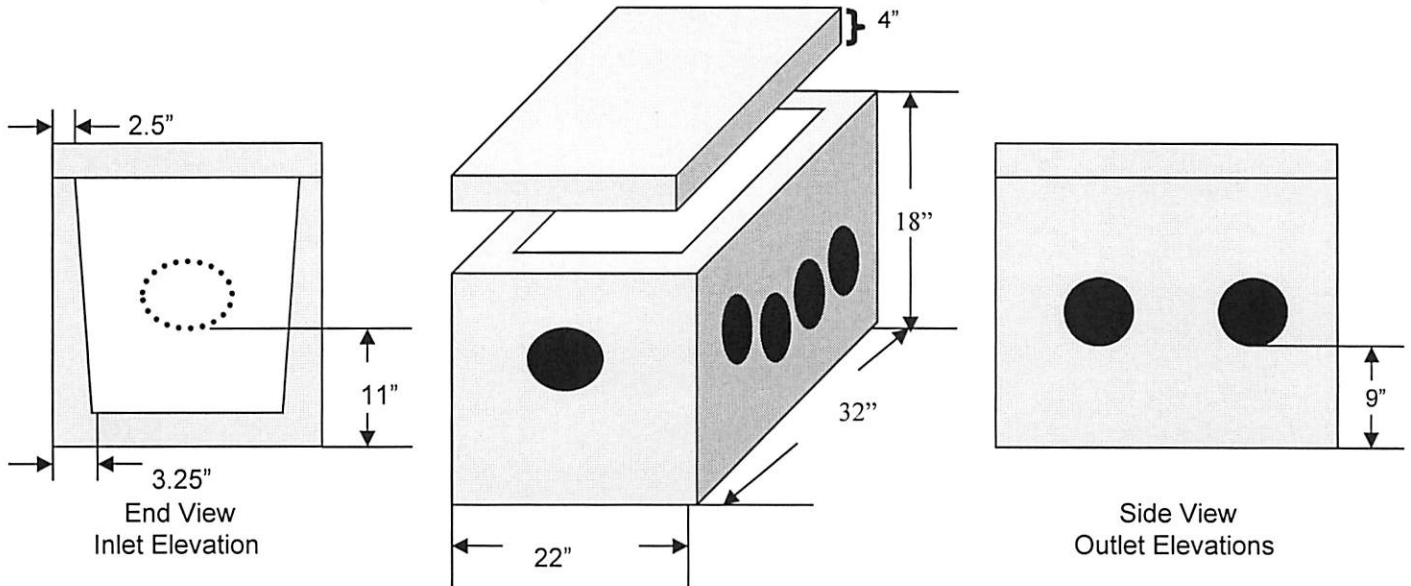

H10 Schematic: H10 cover 2": H20 cover 3"

10 OUTLET (H10 or H20) DISTRIBUTION BOX

(H10 Shown)
(Drawings Not to Scale)

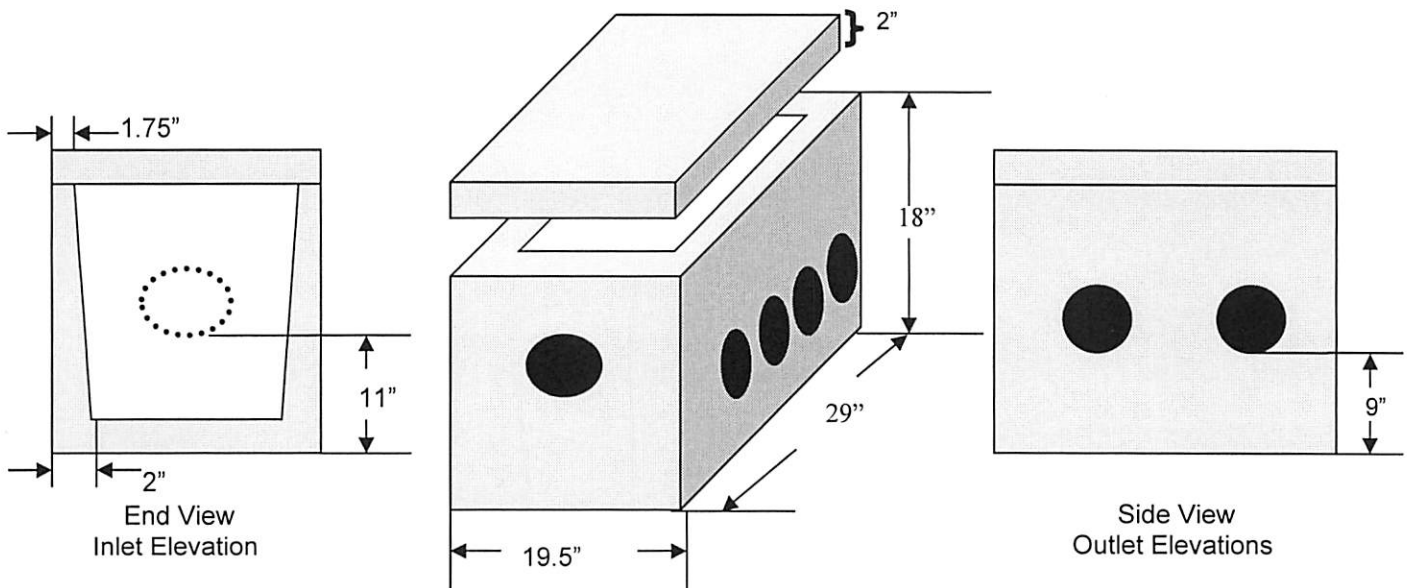

H20 Schematic: H10 cover 2": H20 cover 3"

**For Additional Information See:
Informational Sheet On All Distribution Boxes**