

William N. Lamarre Concrete Products, Inc.

24" ID – H2O TANK EXTENSION

12" and 24" High Risers

Drawing Not to Scale

Covers

**6" Concrete Cover or
24" ID Cast Iron**

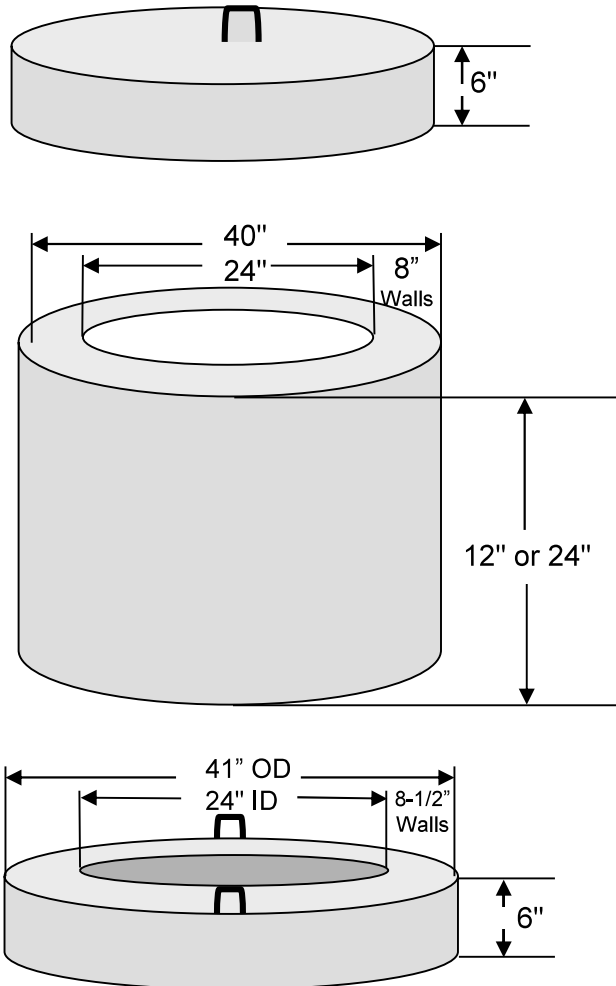

Notes

1. Concrete strength $f'c$ 4000PSI@28 days. Density 150 PCF.
2. Cement, Portland Type II or III, ASTM C150-81
3. Admixtures, air & plasticizers per ASTM C233-82
4. Reinforcement per ASTM C1227-latest revision
5. Construction joints sealed with butyl rubber - optional
6. Design conforms to 310 CMR 15.00, Mass Title V specifications