

William N. Lamarre Concrete Products, Inc.

24" ID – TANK EXTENSION

12" and 24" High Risers

Drawing Not to Scale

Covers

3" Concrete Cover or
3"x24" Medium Duty Cast Iron

Now Available
in H2O
6" Walls
24" ID / 40" OD
1' & 2' height
available

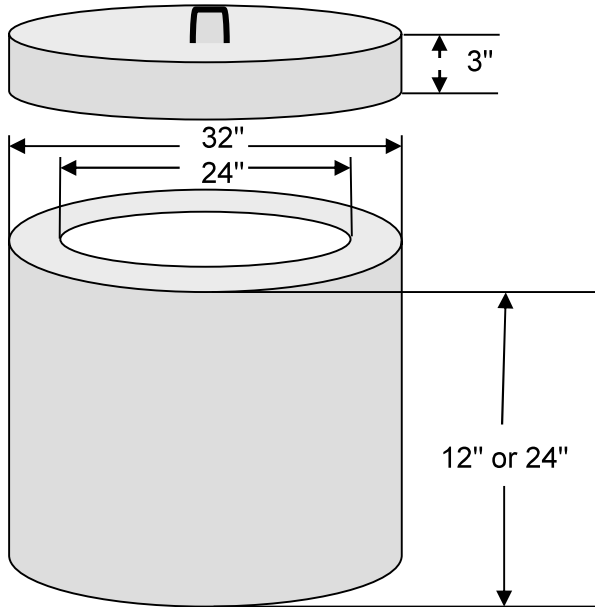

24" ID – GRADE RINGS

4" and 6" High Risers

Drawing Not to Scale

Covers

3" Concrete Cover or
3"x24" Medium Duty Cast Iron

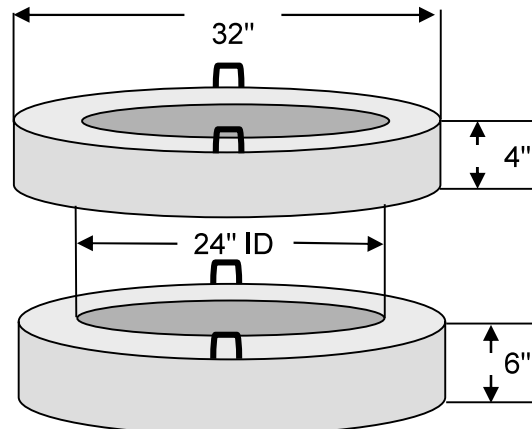

Notes

1. Concrete strength f'_c 4000PSI@28 days. Density 150 PCF.
2. Cement, Portland Type II or III, ASTM C150-81
3. Admixtures, air & plasticizers per ASTM C233-82
4. Reinforcement per ASTM C1227-latest revision
5. Construction joints sealed with butyl rubber - optional
6. Design conforms to 310 CMR 15.00, Mass Title V specifications

87 Adams Hill Road, PO Box #333 Greenville, NH 03048

603-878-1340