

# William N. Lamarre Concrete Products, Inc.

## 24" ID – TANK EXTENSION & GRADE RING, 4" Walls

"New Style" – Tongue and Groove – fits Tank Cleanout Cover

Drawing Not to Scale

### Covers

Fits Standard Tank Cleanout Cover  
Fits Cast Iron Medium or HD

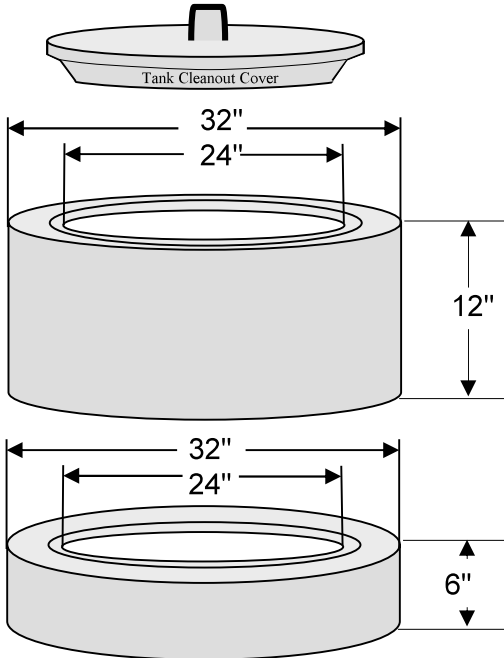

## OVAL COVER & GRADE RING

Fits over center and outlet cleanout on 1000/500, 1250/400, 1500/500, 2000/600  
Measures 59" long x 36" wide

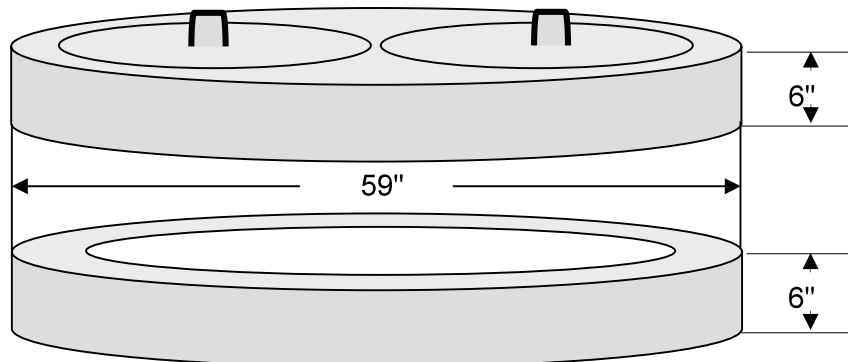

### Notes

1. Concrete strength f'c 4000PSI@28 days. Density 150 PCF.
2. Cement, Portland Type II or III, ASTM C150-81
3. Admixtures, air & plasticizers per ASTM C233-82
4. Reinforcement per ASTM C1227-latest revision
5. Construction joints sealed with butyl rubber - optional
6. Design conforms to 310 CMR 15.00, Mass Title V specifications