

William N. Lamarre Concrete Products, Inc.

H2O TUNNEL TANK – 2 COMP.

Gallons vary to specifications needed.
(Drawings Not to Scale)

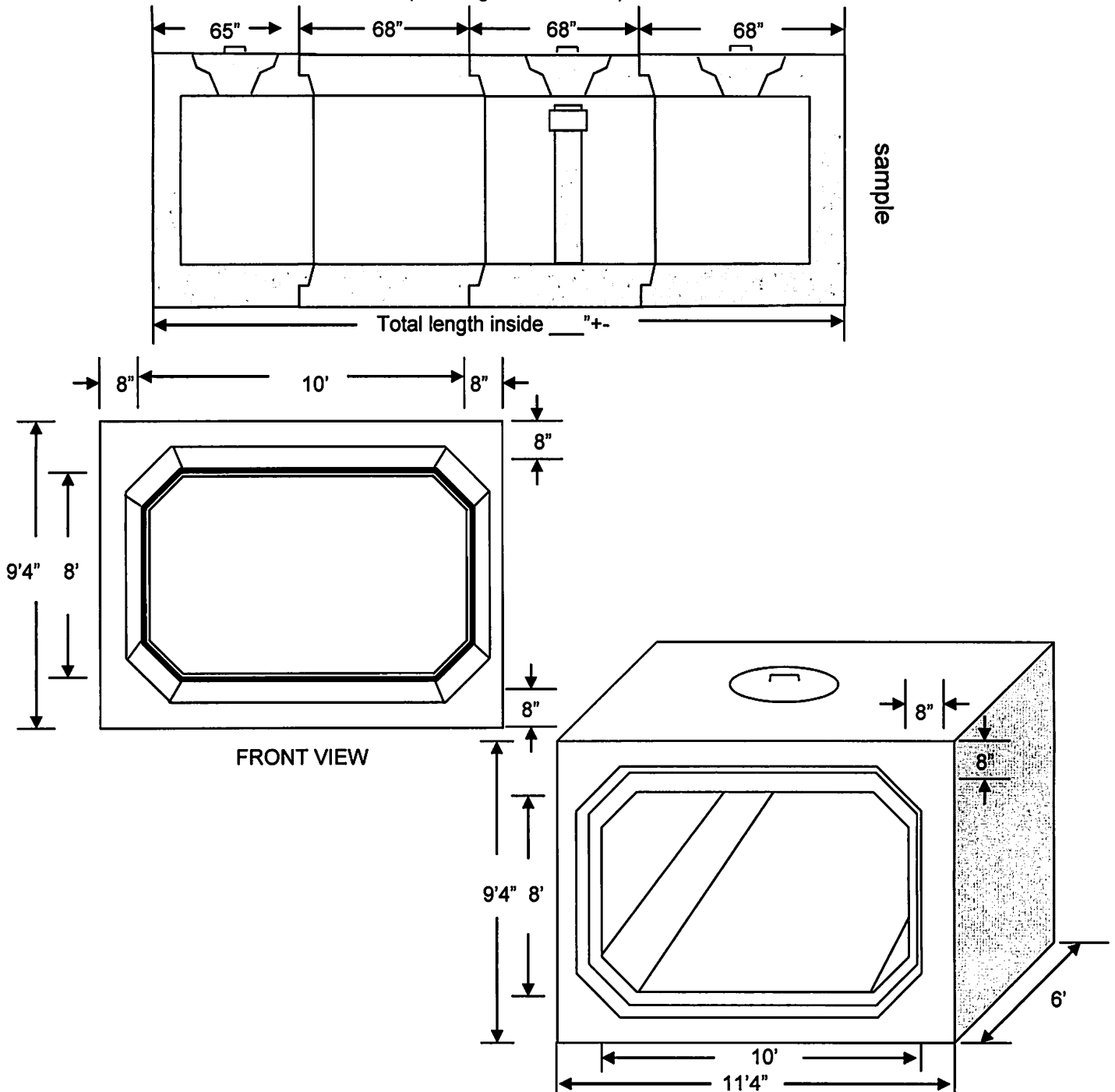

Notes

1. Concrete strength f_c 5000PSI@28 days. Density 150 PCF.
2. Cement, Portland Type II or III, ASTM C150-81
3. Admixtures, air & plasticizers per ASTM C233-82
4. Reinforcement per ASTM C1227-latest revision
5. Design Loading AASHTO HS20-40
6. Construction joints sealed with butyl rubber
7. Design conforms to 310 CMR 15.00, Mass Title V regs. for septic tanks
8. Access & Piping per job specs.