

William N. Lamarre Concrete Products, Inc.

RESIDENTIAL COMBINATION TANKS

H10 OR HD (Top Loading)

(Generic H10 Tank Shown)
Drawing Not to Scale

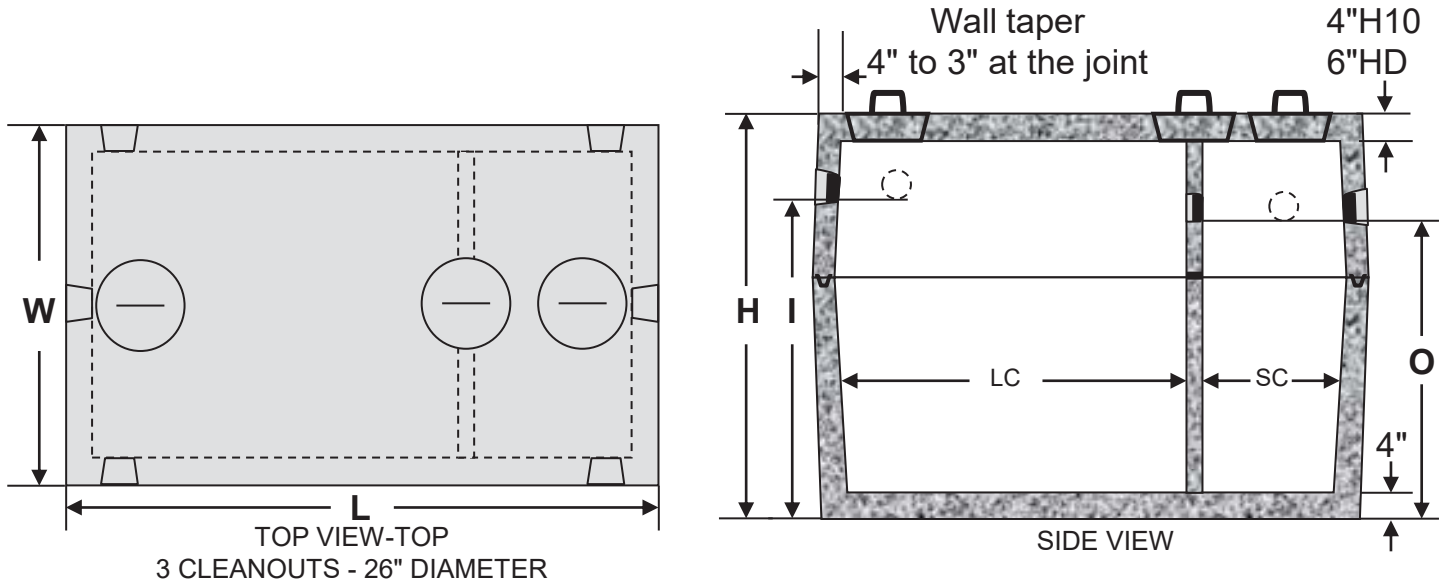

Critical Tank Dimensions					
Liquid Capacity	Inlet/Outlet (I/O)	Height (H) H10/HD	L x W	Long Compartment (LC)	Short Compartment (SC)
1000/500	56"/53"	68"/70"	10'6" x 5'8"	78"	38"
1250/400	47"/44"	60"/62"	12' x 6'6"	102½"	33½"
1500/500	56"/53"	68"/70"	12' x 6'6"	102½"	33½"
2000 (1/3-2/3)	56"/53"	68"/70"	12' x 6'6"	91"	45"
2500 (1/3-2/3)	71"/68"	82½"/84½"	12' x 6'6"	91"	45"
2000/600	74"/71"	93"/95"	12' x 6'6"	102½"	33½"
2000/1000	86"/83"	97½"/99½"	12' x 6'6"	91"	45"

Notes

1. For H20 top-loading add 2" to height.
2. Concrete strength f'c 4000PSI@28 days. Density 150 PCF.
3. Cement, Portland Type II or III, ASTM C150-81
4. Admixtures, air & plasticizers per ASTM C233-82
5. Reinforcement per ASTM C1227-latest revision
6. Heavy-duty top loading available – add 2" to height
7. Construction joints sealed with butyl rubber
8. Design conforms to 310 CMR 15.00, Mass Title V regs. for septic tanks (except 1250-400)