

# William N. Lamarre Concrete Products, Inc.

## H2O TUNNEL TANK

Gallons vary to specifications needed.

Drawing Not to Scale

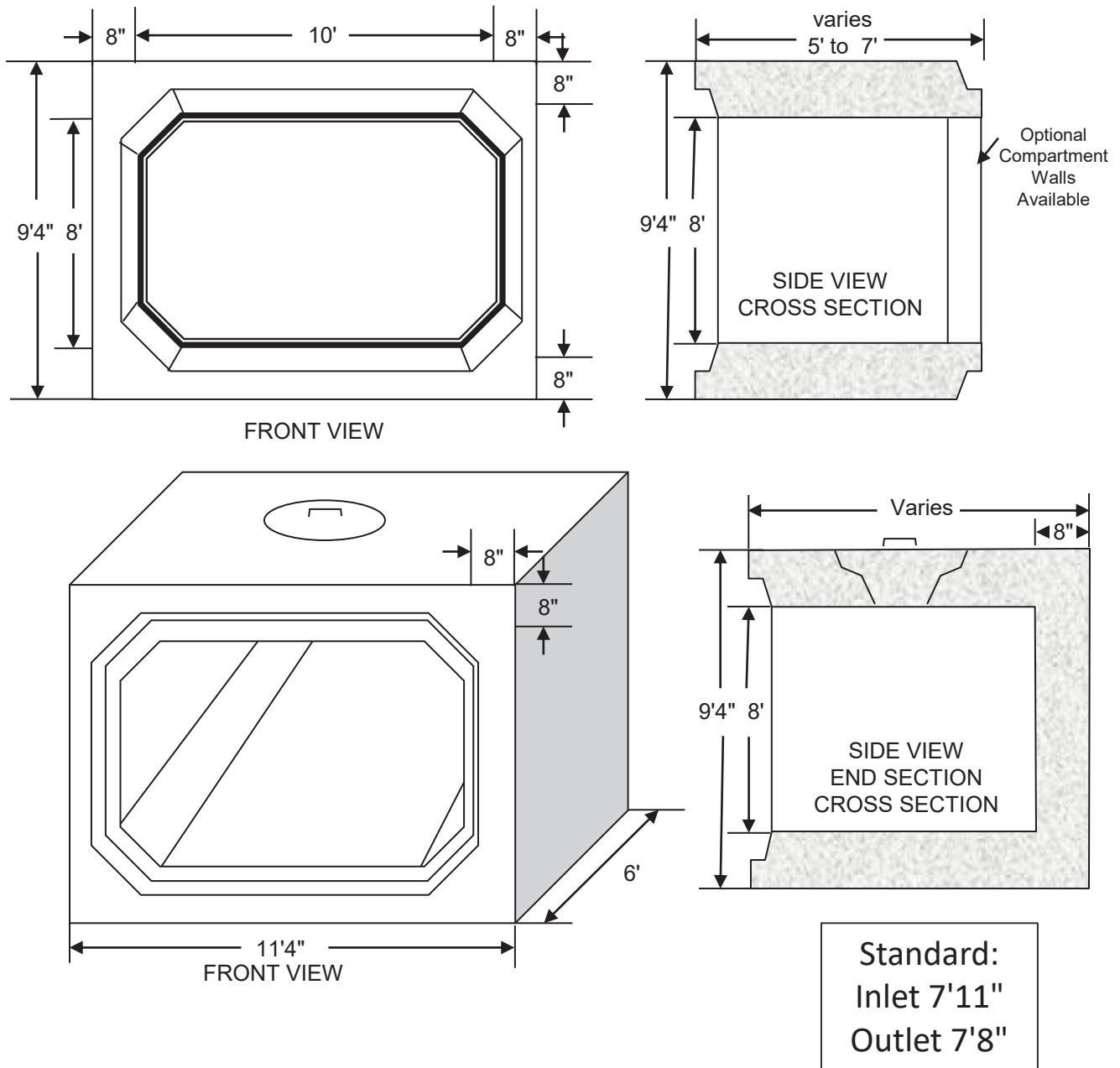

### Notes

1. Available 10,000 to 100,000 Gallon Capacity or more.
2. Concrete strength f'c 5000PSI@28 days. Density 150 PCF.
3. Cement, Portland Type II or III, ASTM C150-81
4. Admixtures, air & plasticizers per ASTM C233-82
5. Reinforcement per ASTM C1227-latest revision
6. Design Loading AASHTO HS20-40
7. Constructions joints sealed with butyl rubber
8. Design conforms to 310 CMR 15.00, Mass Title V regs. for septic tanks
9. Access & Piping per job specs.