

William N. Lamarre Concrete Products, Inc.

45,000 Tunnel Tank – Fire Cistern

Usable Capacity 45,812 +/- Gallons

(Not to Scale)

Actual Location of access holes, etc. to be determined by Fire Dept.*

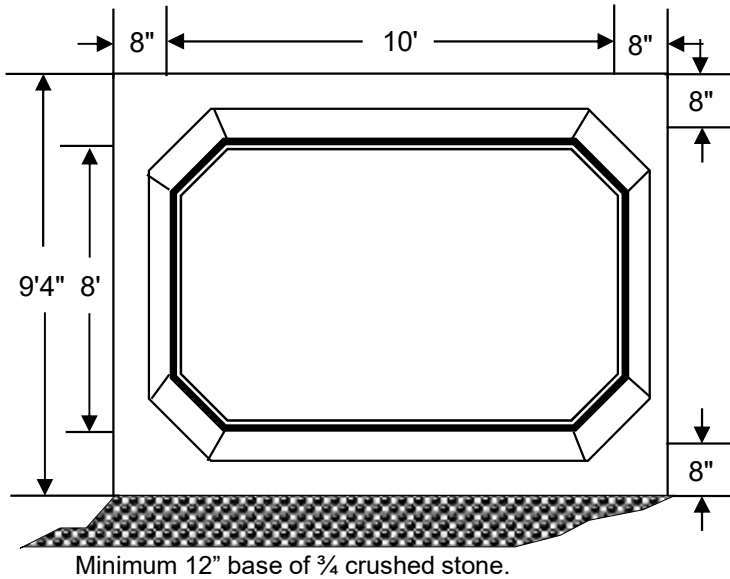
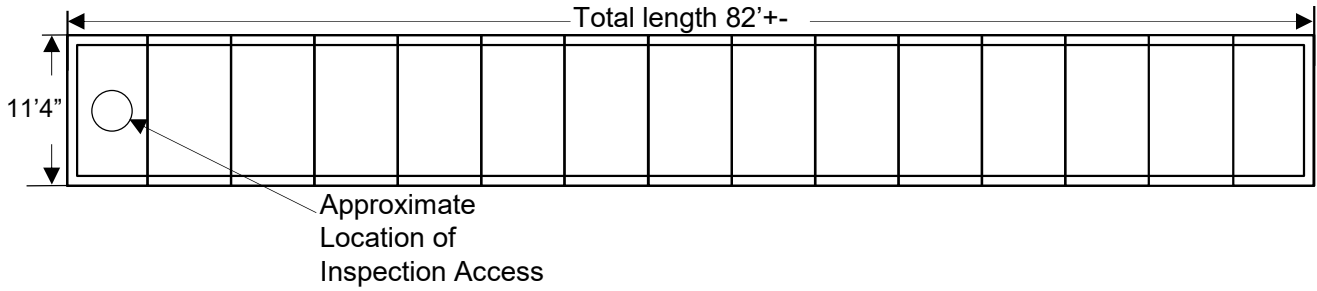

FRONT VIEW

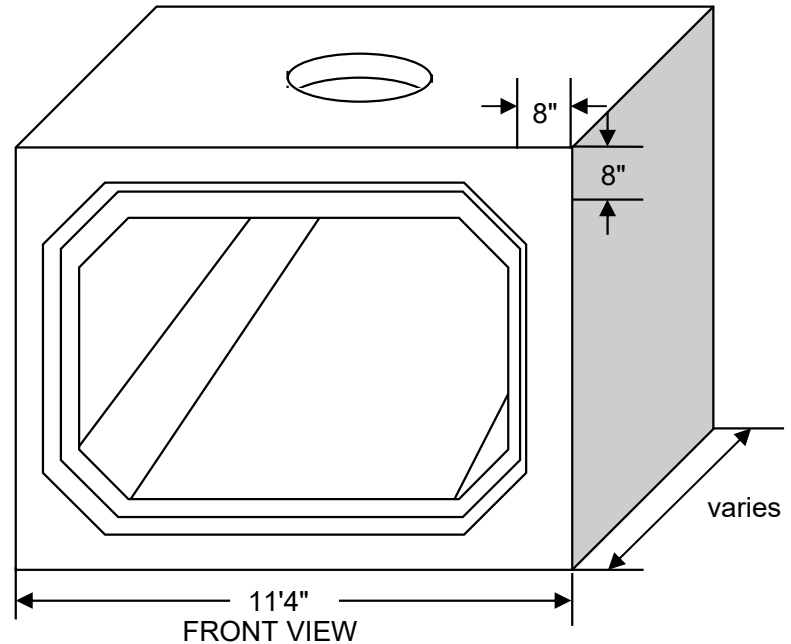

Drawing not to scale.
 Typical: 45,000 gallon tank
 13 - 68" middles
 2 - 48" ends

Notes

1. Concrete strength f'c 5000PSI@28 days. Density 150 PCF.
2. Cement, Portland Type II or III, ASTM C150-81
3. Admixtures, air & plasticizers per ASTM C233-82
4. Reinforcement per ASTM C1227-latest revision
5. Design Loading AASHTO HS20-40
6. Construction joints sealed with butyl rubber
7. Design conforms to 310 CMR 15.00, Mass Title V regs. for septic tanks
8. Access & Piping per job specs.